



- kinnistu piir
- projekteeritav elamu
- olemasolev hoone
- lammutatavad hooned
- projekteeritud terrassid
- projekteeritud kivisillutis
- projekteeritud murukivi
- III väärtusklassi puittaim
- IV väärtusklassi puittaim
- mahavõetav puu
- prügikonteineri asukoht
- projekteeritud kinnistu kanalisatsioonitoru
- olemasolev kanalisatsioonitoru
- projekteeritud kinnistu veetoru
- olemasolev veetrass
- projekteeritud 0,4 kV maakaabel
- projekteeritud mõõtekilp
- puitaed
- kõrgepingekaabel
- möödistatud ala piir

TEHNILISED NÄITAJAD:

KRUNT:
 Krundi sihtotstarve.....EE100%
 Krundi pind.....1958 m²
 Ehitisalune pind.....267,5m²
 - garaaz.....34m²
 - majandushoone.....45m²
 - kelder.....20m²
 - proj.elamu.....168,5m²
 täisehitusprotsent.....13,6
 haljastuse protsent.....70
 parklakohti.....3

ÜSIKELAMU:
 Korruselisus.....1
 Ehitisalune pind.....168,5m²
 Suletud netopind.....147,2 m²
 -eluruumide pind.....142,2 m²
 -tehnopind.....5,0 m²
 Hoone maht.....637,2 m³
 Hoone eluiga.....50 aastat
 Tulepüsimusklass.....TP3

HOONE NURGAPUNKTIDE KOORDINAADID

Punkt	X	Y
N1	6582460.02	536517.20
N2	6582475.71	536521.44
N3	6582473.70	536528.87
N4	6582454.42	536523.67
N5	6582455.47	536519.79
N6	6582459.06	536520.76

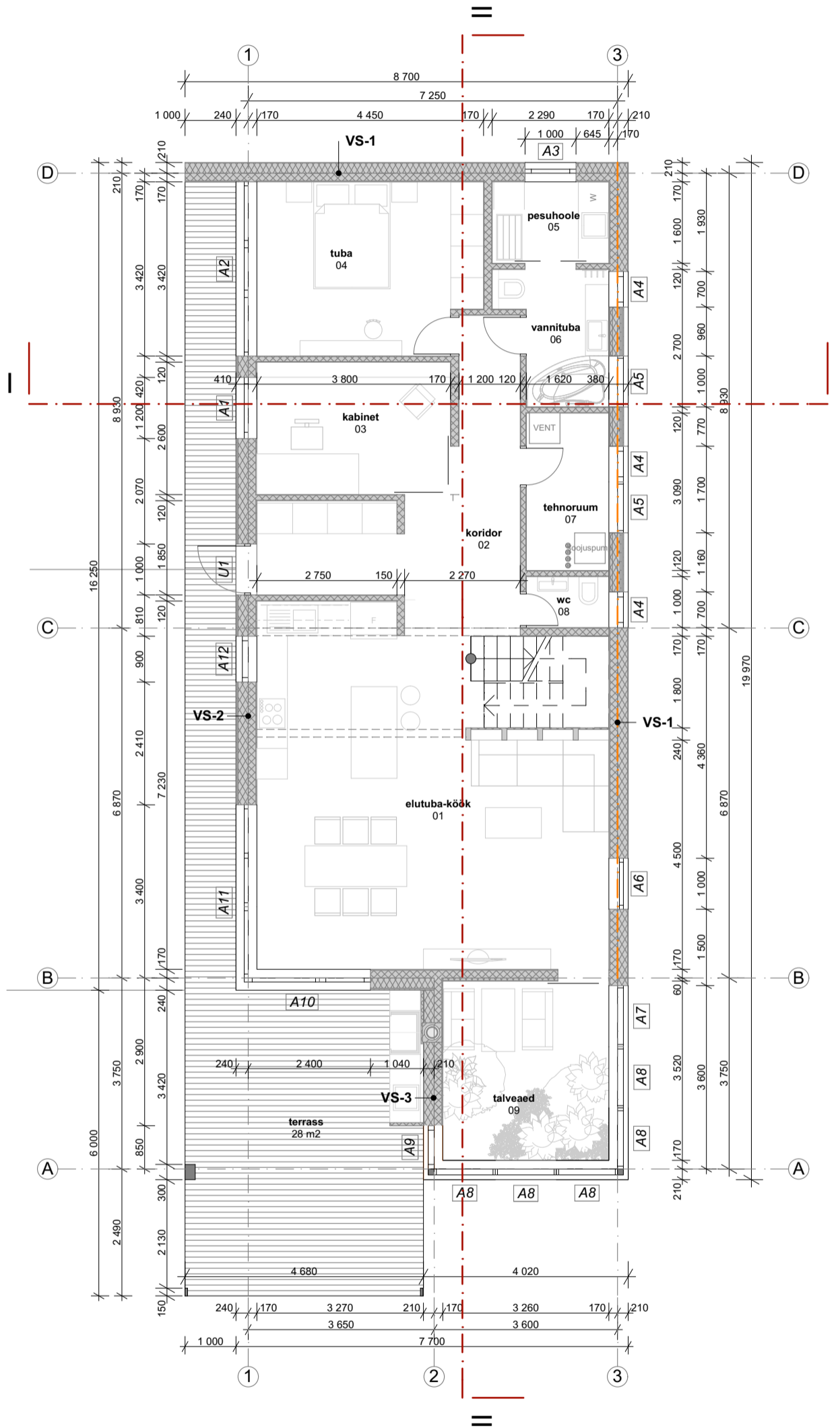

	VS-1	
	- krohv.....	10
	- eps	200
	- kergplokk.....	150
	- krohv/viimistlus.....	20
	kokku.....	380

	VS-2	
	- voodrilaud	20
	- õhkvahe, roov.....	20
	- eps/termoroov	200
	- kergplokk.....	150
	- krohv/viimistlus.....	20
	kokku.....	410

	SS-1	
	- krohv/viimistlus.....	25
	- kergplokk.....	150
	- krohv/viimistlus.....	25
	kokku.....	200

	SS-2	
	- krohv/viimistlus.....	10
	- kergplokk.....	100
	- krohv/viimistlus.....	10
	kokku.....	120

MÄRKUSED:

Aknad A5, A6
- tuletõkkeaken EI30
(Aru Fix Firestop)
Aknad A4 - < 0,2m²
avatavad aknad

tuletõkksein EI60

RUUMIDE EKSPLIKATSIOON:

01 elutuba-köök.....	41.5
02 koridor.....	15.7
03 kabinet.....	9.9
04 tuba.....	14.6
05 pesuhoole.....	3.7
06 vannituba.....	4.9
07 tehnooruum.....	5.0
08 wc.....	1.6
09 talveaed.....	11.5

KOKKU: 108.4

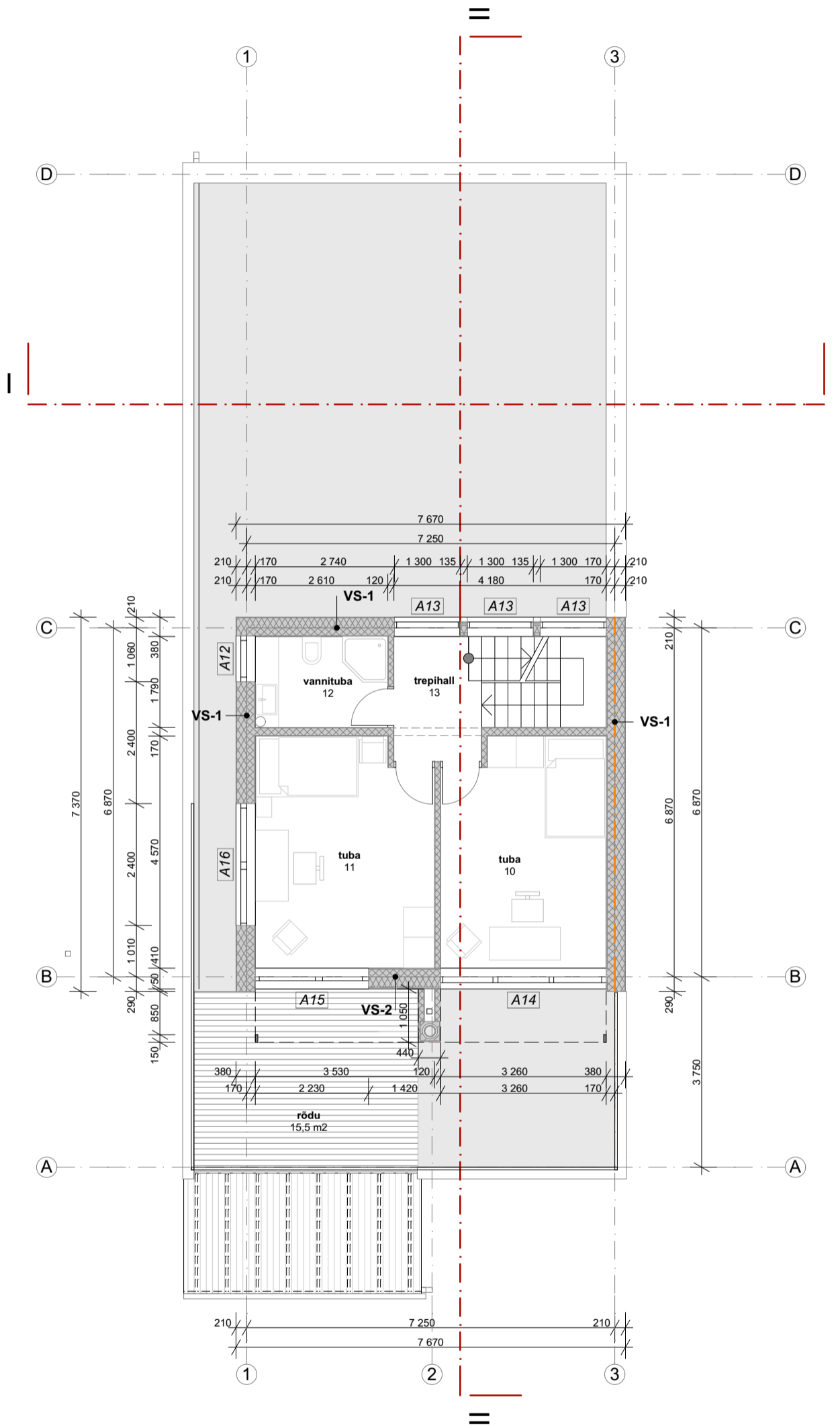

	VS-1	
	- krohv.....	10
	- eps	200
	- kergplokk.....	150
	- krohv/viimistlus.....	20
<hr/>		
	kokku.....	380

	VS-2	
	- voodilaud	20
	- õhkvahe, roov.....	20
	- eps/termoroov	200
	- kergplokk.....	150
	- krohv/viimistlus.....	20
<hr/>		
	kokku.....	410

	SS-1	
	- krohv/viimistlus.....	25
	- kergplokk.....	150
	- krohv/viimistlus.....	25
<hr/>		
	kokku.....	200

	SS-2	
	- krohv/viimistlus.....	10
	- kergplokk.....	100
	- krohv/viimistlus.....	10
<hr/>		
	kokku.....	120

MÄRKUSED:





--- tuletõkksein EI60

RUUMIDE EKSPLIKATSIOON:

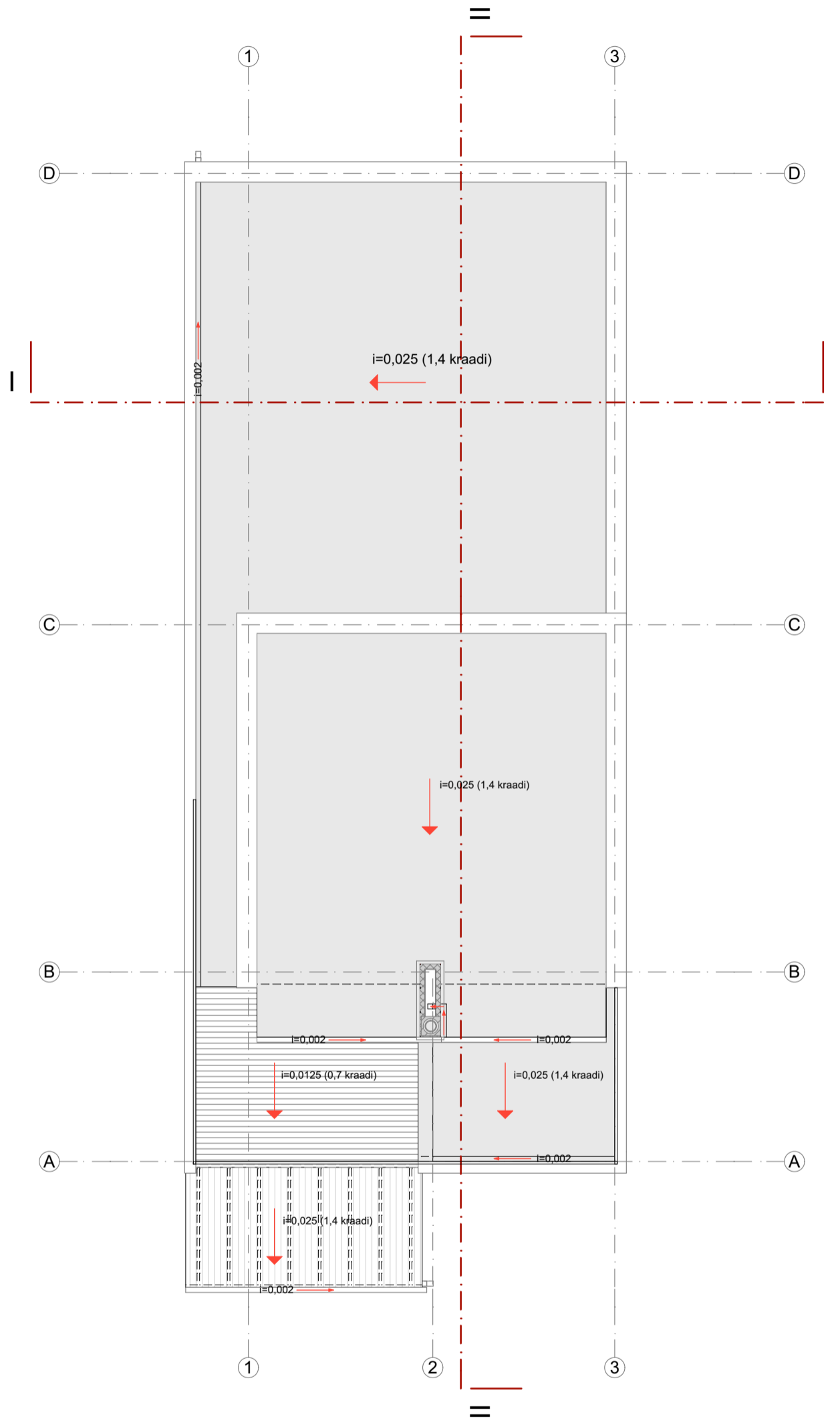
10 tuba.....	14.3
11 tuba.....	15.6
12 vannituba.....	4.7
13 trepihall.....	4.2

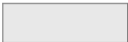
KOKKU: 38.8

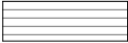

-  - SBS bit. rullmaterjal
-  - valguskatus (läbipaistev PVC)
-  - puitrest rullmaterjalil
-  - parapett (katteplekk RR23)

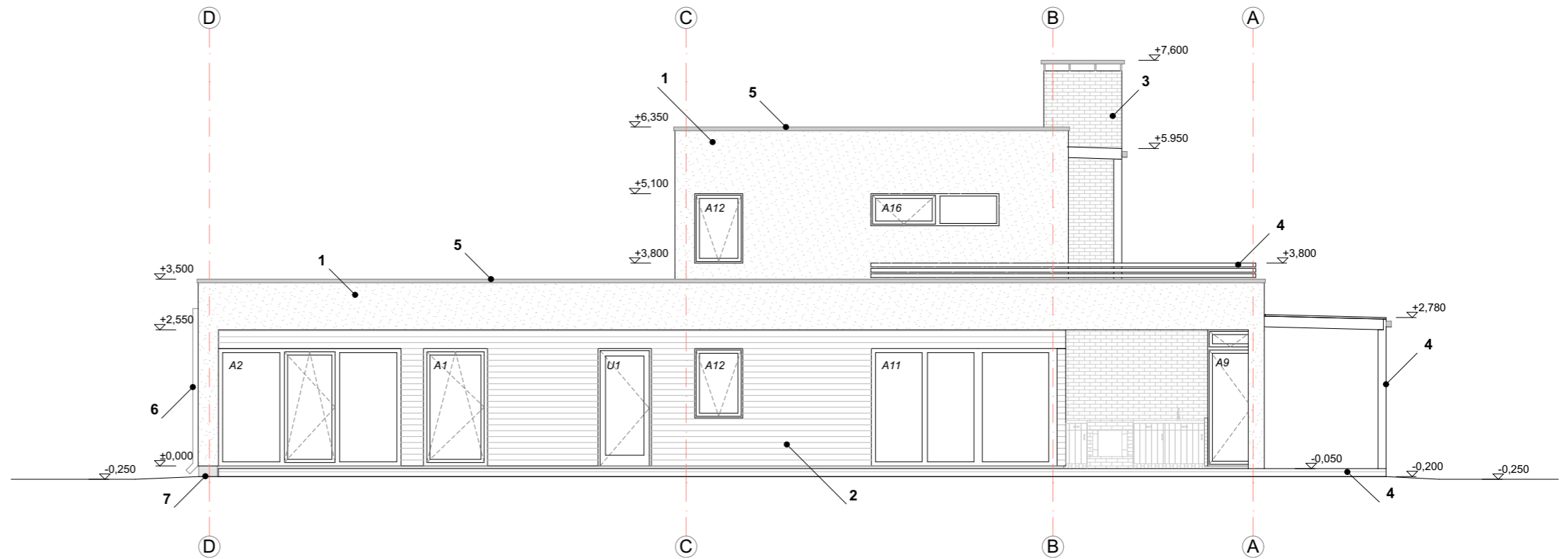

VAADE LÄÄNEST

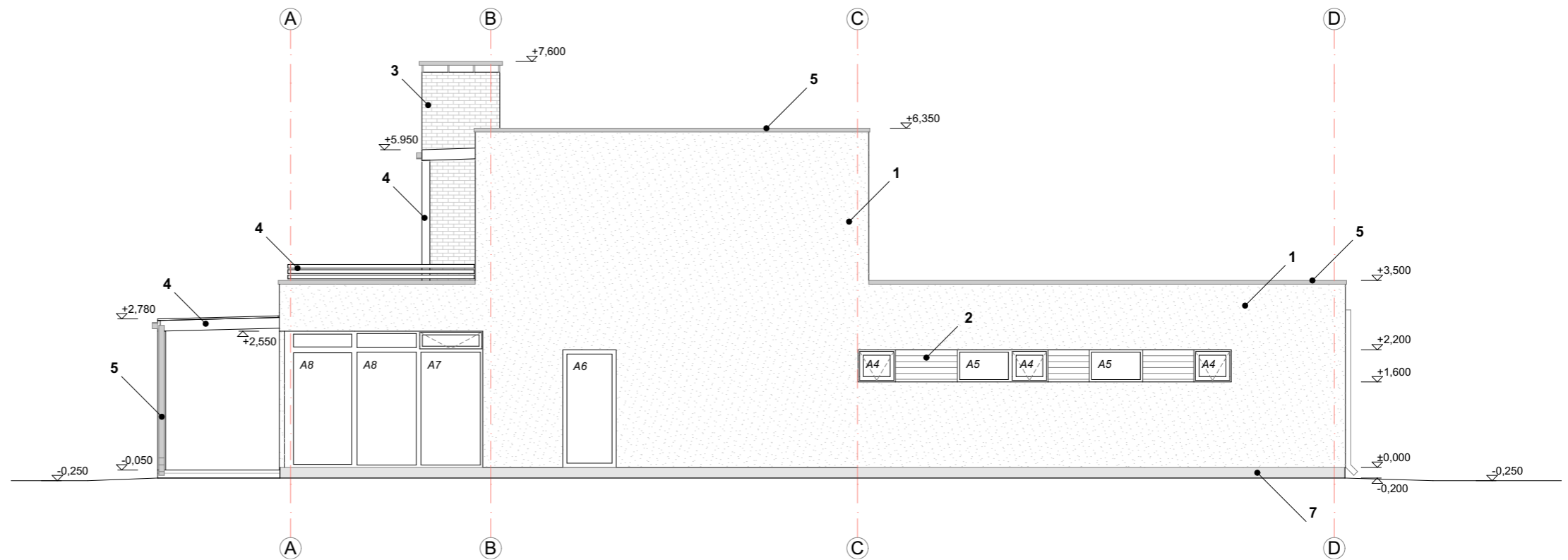

VAADE IDAST

- 1 - krohv TIKKURILA FACADE 4938
- 2 - laudis siberi lehis, töötlus - raudsulfaat
- 3 - keraam.tellis Vandersanden "Leto" või sarnane - tumehall
- 4 - puitdetailid ja konstr. elemendid lasuurvärn Remmers RC3
- 5 - katuseplekid ja vihmaveesüsteem RR23
- 6 - vihmaveesüsteem RR20
- 7 - krohv v sokliplaat RAL 7023

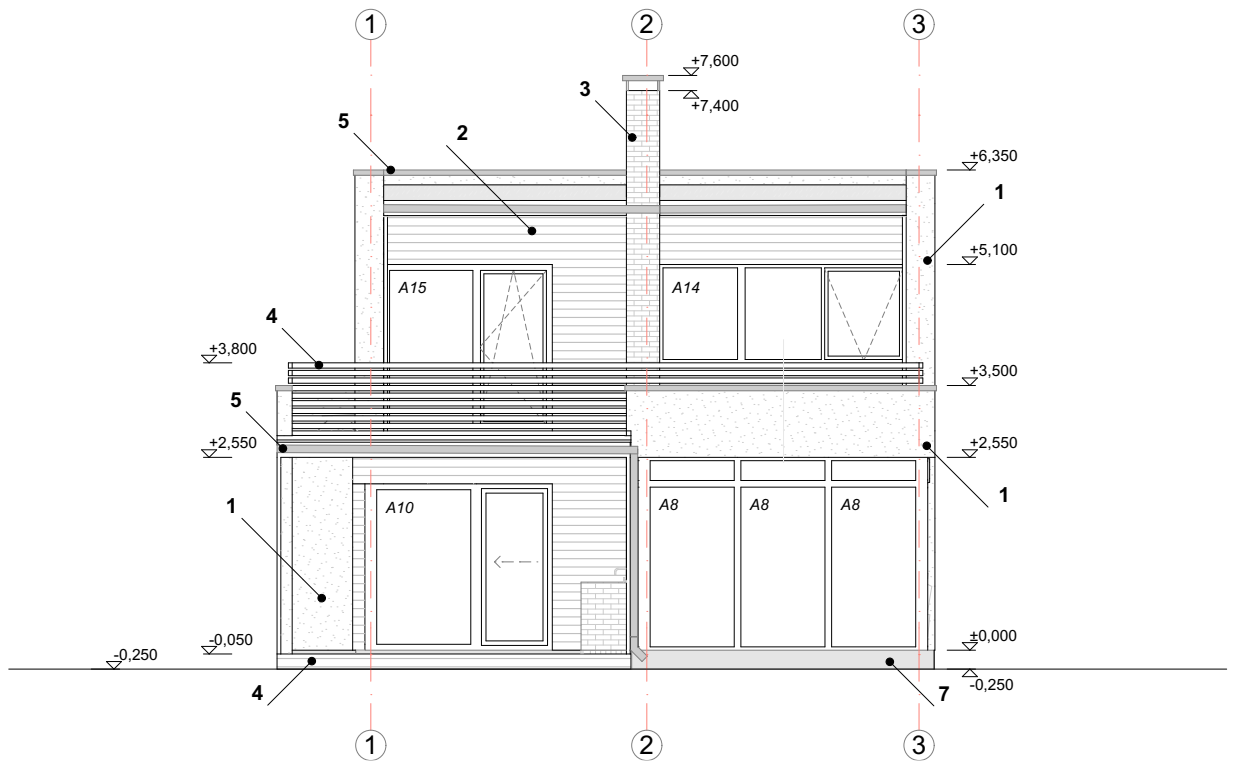

VAADE LÖUNAST

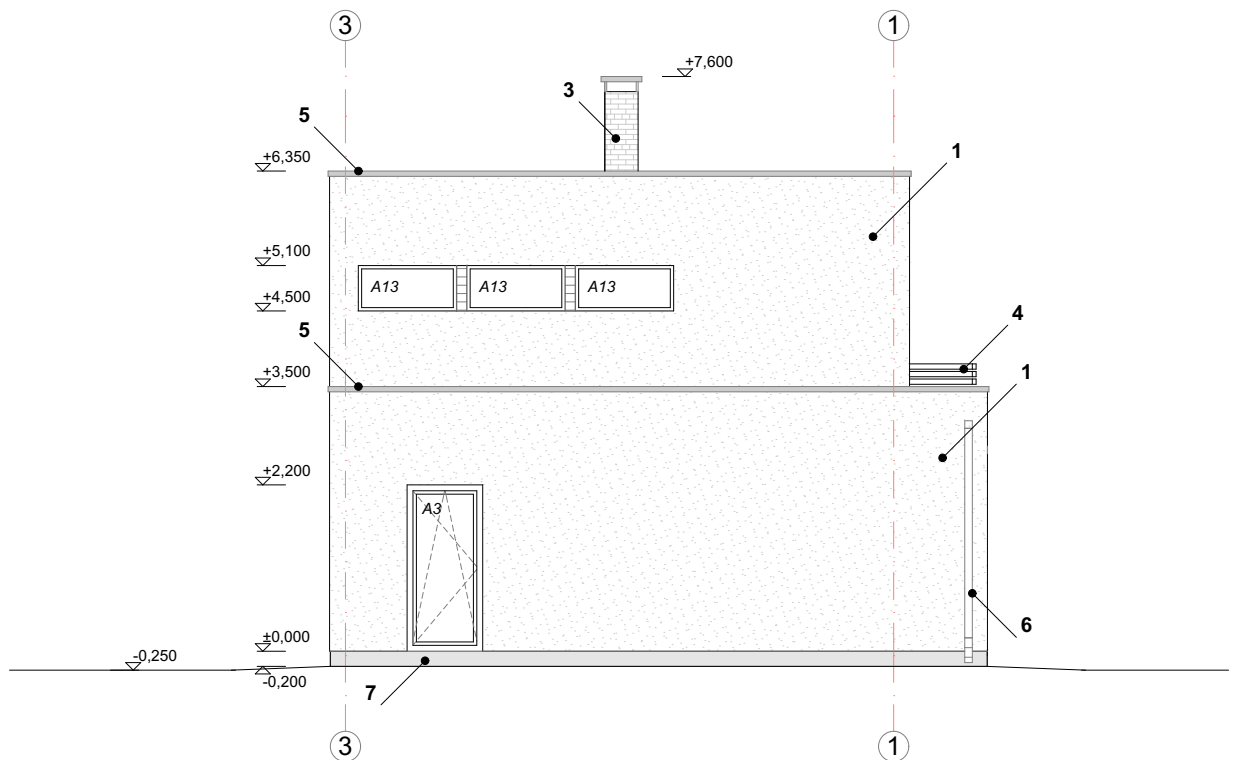

VAADE PÕHJAST

- 1 - krohv TIKKURILA FACADE 4938
- 2 - laudis siberi lehis, töötlus - raudsulfaat
- 3 - keraam.tellis Vandersanden "Leto" või sarnane - tumehall
- 4 - puitdetailid ja konstr. elemendid lasuuvärv Remmers RC3

- 5 - katuseplekid ja vihmaveesüsteem RR23
- 6 - vihmaveesüsteem RR20
- 7 - krohv v sokliplaat RAL 7023

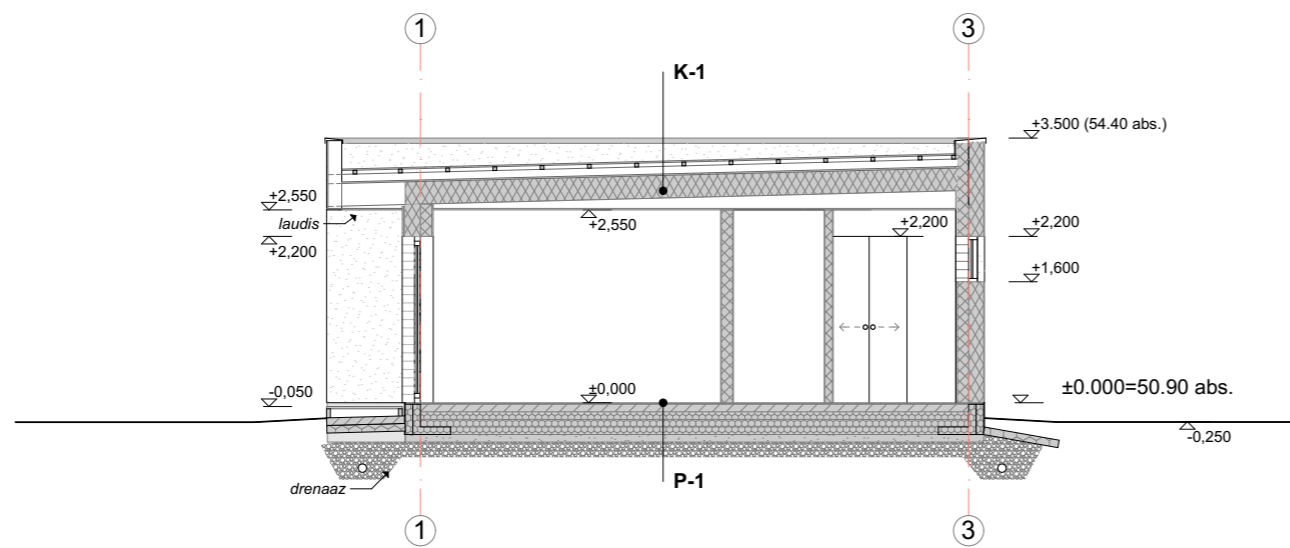

- P-1**
- põr.kate (naturaalne parkett)
 - plaatvundament (monol. r/b)
 - hüdroisolatsioon
 - vahtpolüstüreen 300mm
 - tihendatud liiv
 - killustikalus

- VL-1**
- põr.kate (nat.parkett v ker.plaat).....20
 - osb plaat.....20
 - hõre laudis/põrandaküte.....20
 - puit-met.tala/klaasvill.....250
 - roov.....20
 - voodrilaud.....20
- kokku.....350

- K-1**
- SBS bituumen 2 kihti
 - osb plaadil20
 - roov 45x45.....50
 - distantsroov 50x100.....100
 - tuuletõkkeplaat.....20
 - puit-met.tala/klaasv.....300
 - aurutõke
 - ripplae karkass 50x20-230.....20-230
 - voodrilaud.....20
- kokku.....530-740

- K-2**
- SBS bituumen 2 kihti
 - osb plaadil20
 - roov 45x45.....50
 - distantsroov 50x100.....100
 - tuuletõkkeplaat.....20
 - puit-met.tala/klaasv.....250
 - aurutõke
 - ripplae karkass/kl.vill50 50x50-140.....50-140
 - voodrilaud.....20
- kokku.....510-600



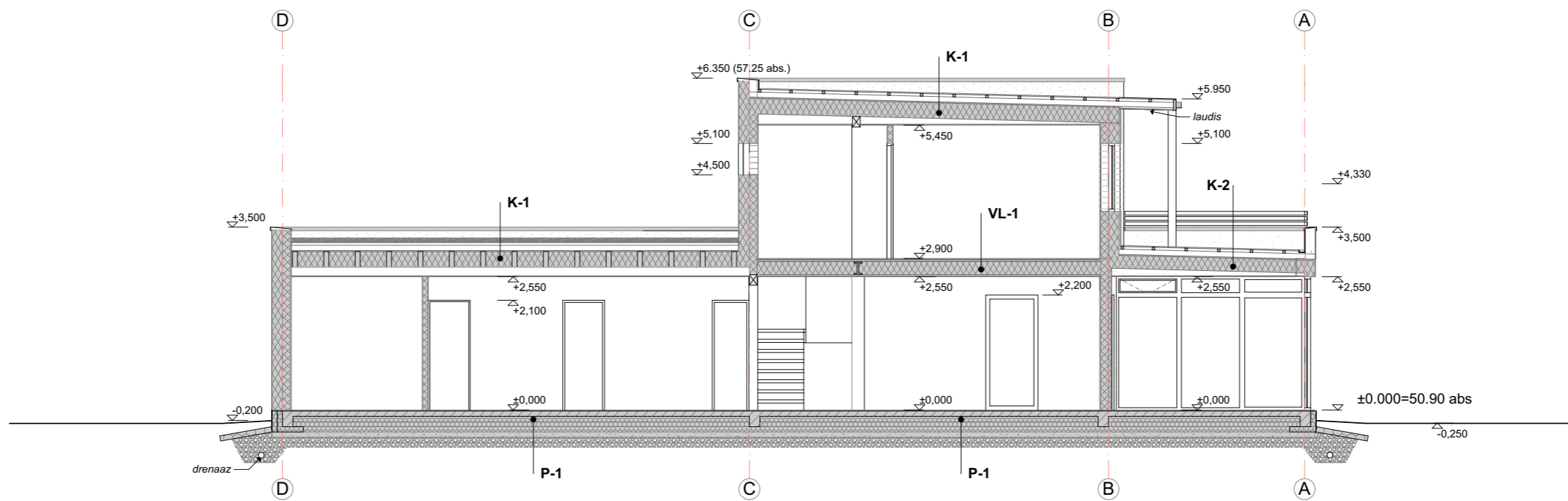

LÕIGE I-I



LÕIGE II-II

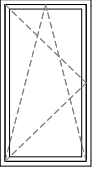
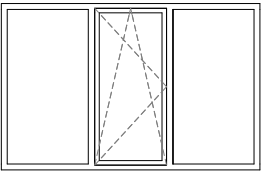
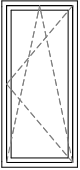

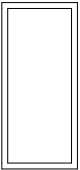

VÄLISAVATÄITED, AKNAD

- kõik mõõdud täpsustada tegeliku ehitise järgi
- avade vaated antud väljaspoolt
- puitaknad
- 3 kordne klaaspakett
- klaas kirgas, sisemine klaas selektiivklaas
- lasuurvärv väljas ja sees, Remmers RC3

tähis	skeem	avamõõdud L x H (täpsustada)	märkused
A1		1 200x2 200	Puitaken-rõduuks, Aru 78 Softline IN PÖÖRD-JA KALDAVATAV
A2		3 420x2 200	Puitaken, Aru 78 Softline IN üks osa PÖÖRD-JA KALDAVATAV
A3		1 000x2 200	Puitaken-rõduuks, Aru 78 Softline IN PÖÖRD-JA KALDAVATAV
A4		700x600	Puitaken, Aru 78 Modern EX ALT-PÖÖRDAVANEV Kogus: 3tk.
A5		1 000x600	Tuletõkkeaken, Aru Fix Firestop EI30, MITTEAVATAV Kogus: 2tk.
A6		1 000x2 200	Tuletõkkeaken, Aru Fix Firestop EI30, MITTEAVATAV
A7		1 200x2 550	Puitaken, Aru 78 Modern EX ülemine osa ALT-PÖÖRDAVANEV

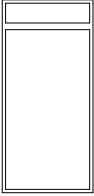
VÄLISAVATÄITED, AKNAD

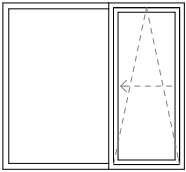
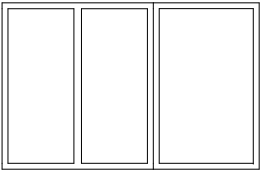
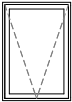
- kõik mõõdud täpsustada tegeliku ehitise järgi
- avade vaated antud väljaspoolt
- puitaknad
- 3 kordne klaaspakett
- klaas kirkas, sisemine klaas selektiivklaas
- lasuurvärv väljas ja sees, Remmers RC3

tähis	skeem	avamõõdud L x H (täpsustada)	märkused
A8		1 200x2 550	Puitaken, Aru 78 Modern EX MITTEAVATAV Kogus: 5tk.
A9		850x2 200	Puitaken-rõduuks, Aru 78 Modern EX ülemine osa ALT-PÖÖRDAVANEV alumine osa PÖÖRDAVANEV VASAK KÄSI
A10		1 000x2 200	Puitaken, Aru 78 Softline IN üks osa KALD-LIUGAVANEV
A11		2 000x2 200	Puitaken, Aru 78 Softline IN MITTEAVATAV
A12		900x1 300	Puitaken, Aru 78 Modern EX üks pool ALT-PÖÖRDAVANEV Kogus: 2tk.
A13		1 300x600	Puitaken, Aru 78 Modern EX MITTEAVATAV Kogus: 3tk.

VÄLISAVATÄITED, AKNAD

- kõik mõõdud täpsustada tegeliku ehitise järgi
- avade vaated antud väljaspoolt
- puitaknad
- 3 kordne klaaspakett
- klaas kirgas, sisemine klaas selektiivklaas
- lasuurvärv väljas ja sees, Remmers RC3

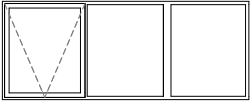
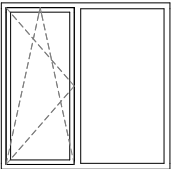
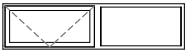
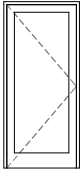
tähis	skeem	avamõõdud L x H (täpsustada)	märkused
A14		3 260x1 300	Puitaken, Aru 78 Modern EX üks pool ALT-PÖÖRDAVANEV
A15		2 230x2 200	Puitaken, Aru 78 Softline IN üks pool PÖÖRD-JA KALDAVATAV
A16		2 400x600	Puitaken, Aru 78 Modern EX üks pool ALT-PÖÖRDAVANEV
U1		1 000x2 200	Välisuks, Aru ED S-78 Modern EX VASAK KÄSI

Lõige 1-1
Proj. kivistatud ühildumine tänava
katendiga

